

Optimizing Lens Choices for Digital Cinema

Dwight Lindsey

Waste Not – Want Not

- Use all the pixels
- Use all the brightness
- Use all the contrast
- Use all the sharpness (resolution)
- Use all the image circle (distortion correction)

Use All the Pixels

- We have two common movie formats
 - Widescreen 1.85 aspect ratio
 - Cinemascope 2.39 aspect ratio
- They are not the same shape as the 2K or 4K chips
- We have two ways of presenting the image at the screen
 - Constant Height
 - Constant Width
- There is no “lens turret” available to change lenses
- Anamorphic Lenses are “forbidden”
- Zoom lenses don’t always allow a format change

Two Ways of Masking Screen Constant Height

1.85 format

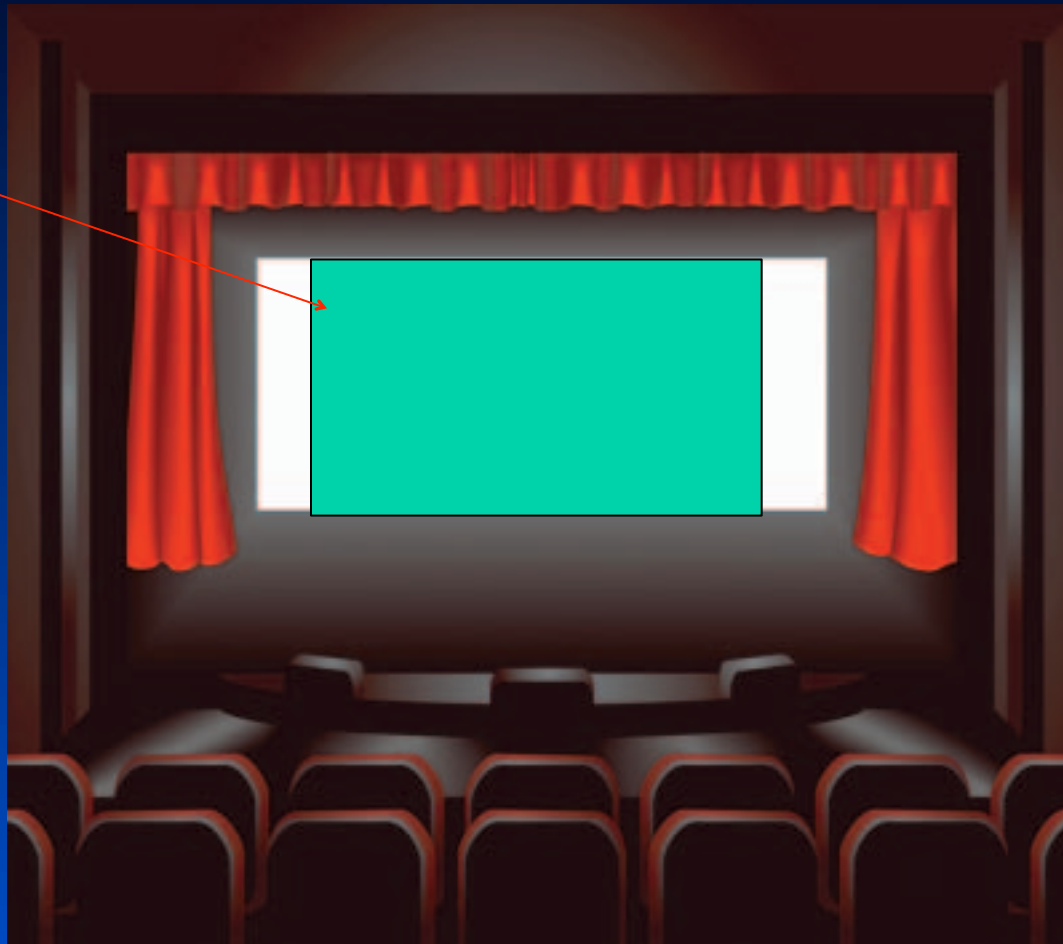

Two Ways of Masking Screen Or. . . Constant Width

2.39 format

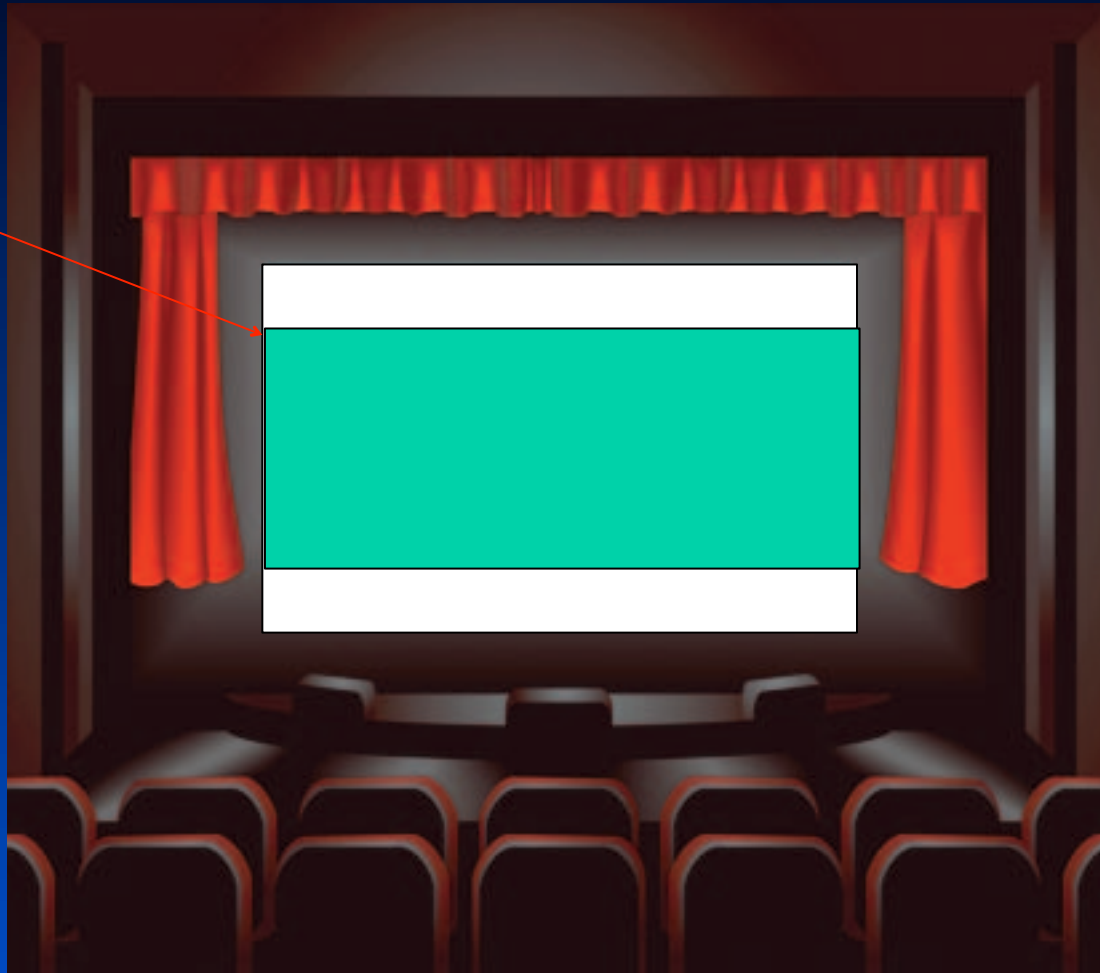

2K Chip – 1.896 Aspect Ratio

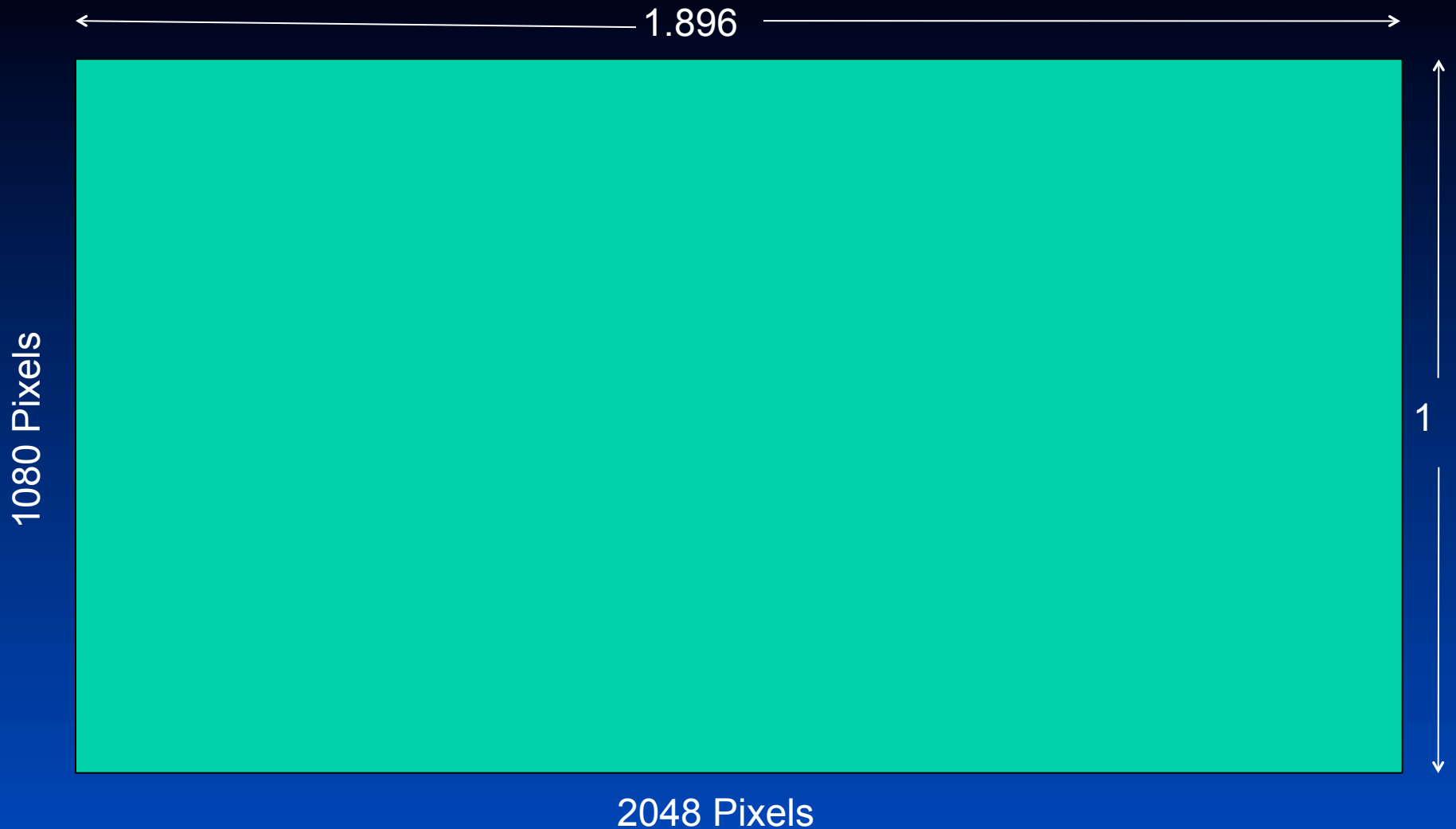

Two Formats



Cinemascope
1:2.39 Aspect Ratio



Widescreen 1.85
1:1.85 Aspect Ratio

Constant Height No Lens Change or Anamorphic

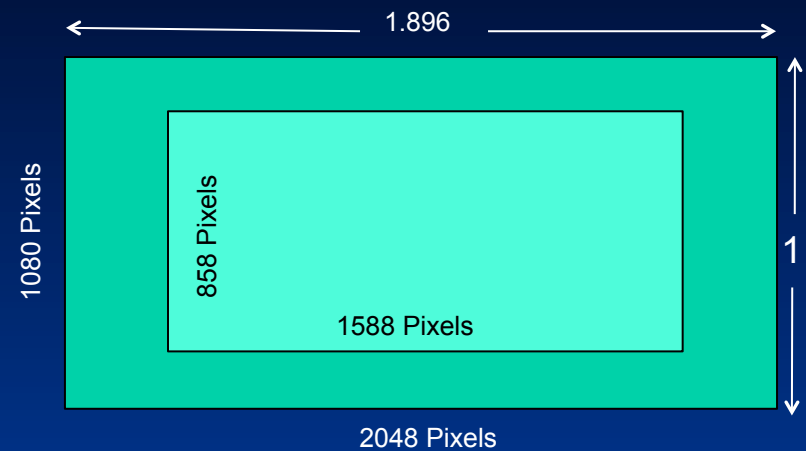
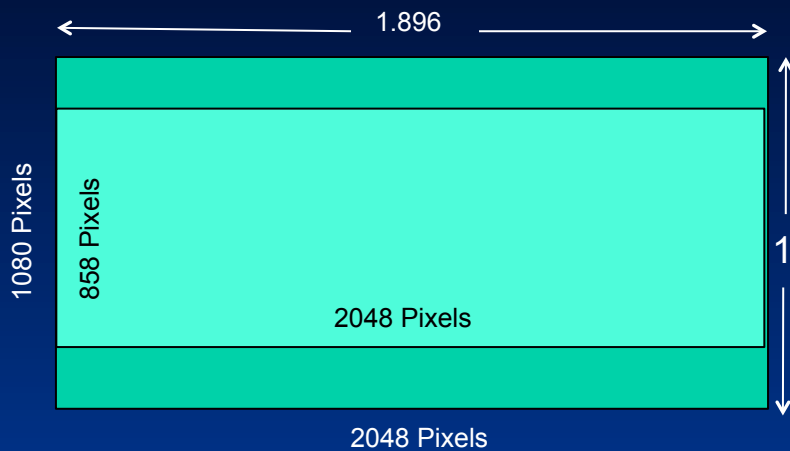

Lens Must Change Focal Length by 25%
If not the 1.85 Image is LOW resolution!

Constant Height – With Lens Change

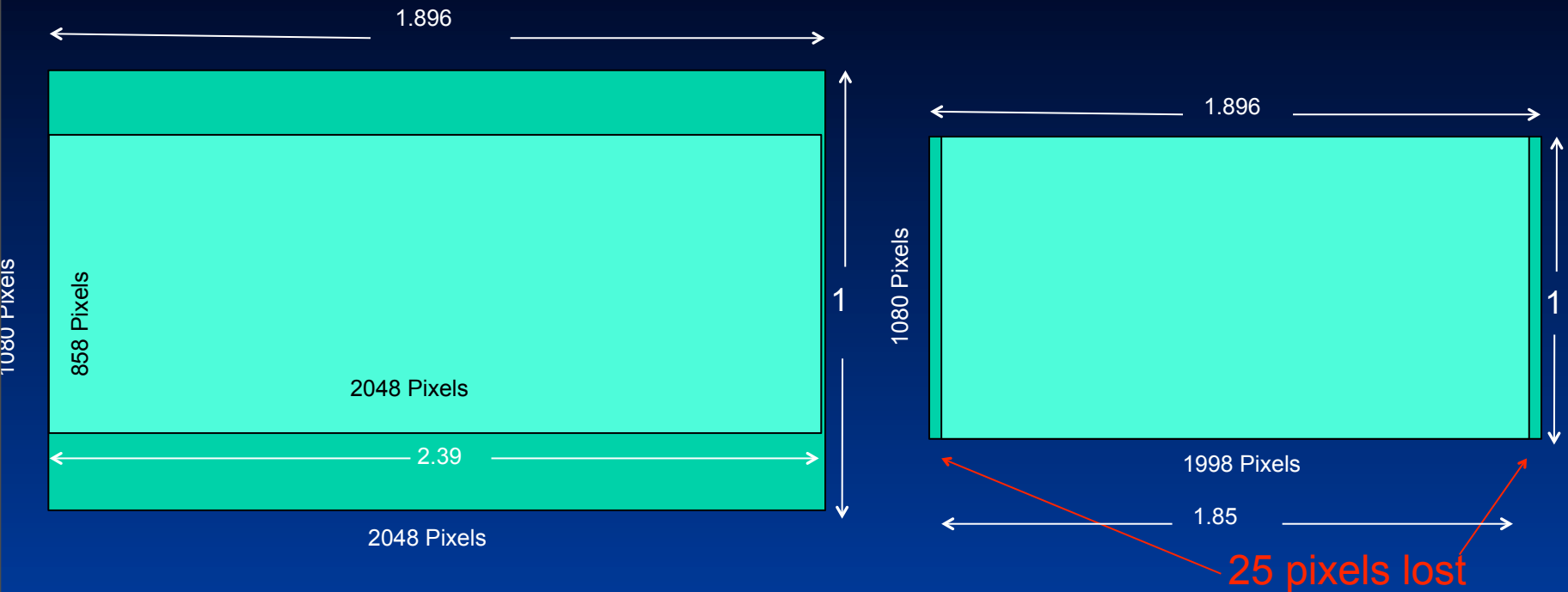

Lens Must Change Focal Length by 25%
1.85 Image is High Resolution
2.39 Cinemascope lower resolution than the 1.85 image

Constant Height – With Anamorphic

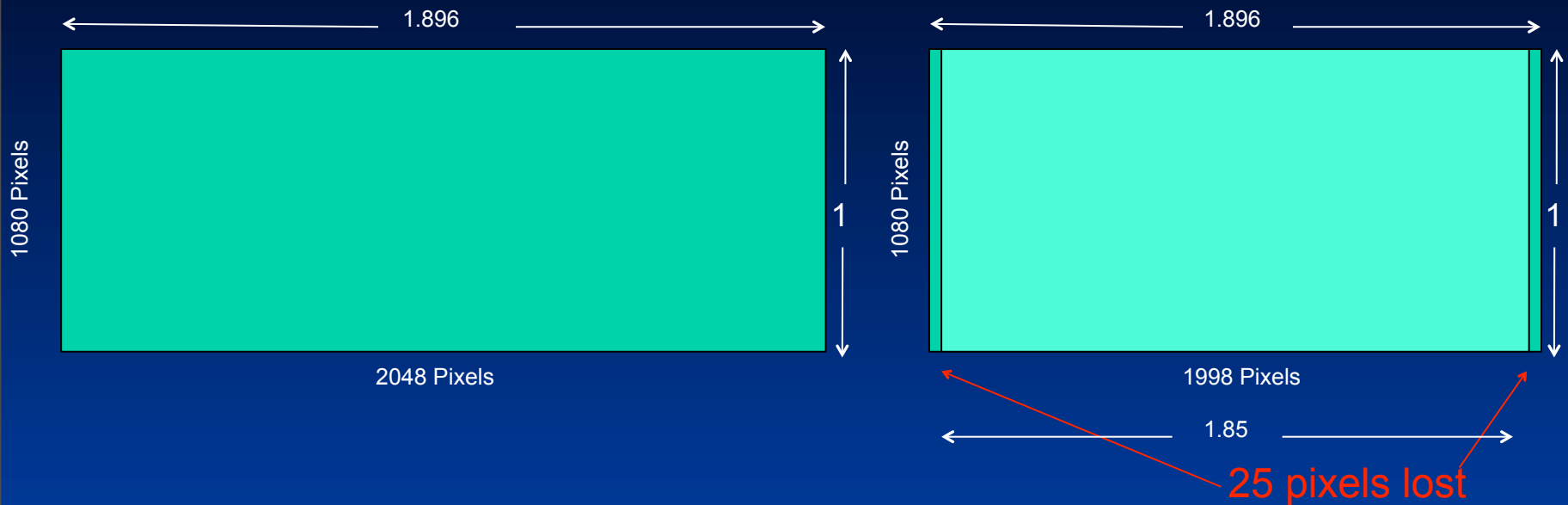

Lens Focal Length Does Not Change
Anamorphic Lens is Used

Constant Width – No Lens Change Needed

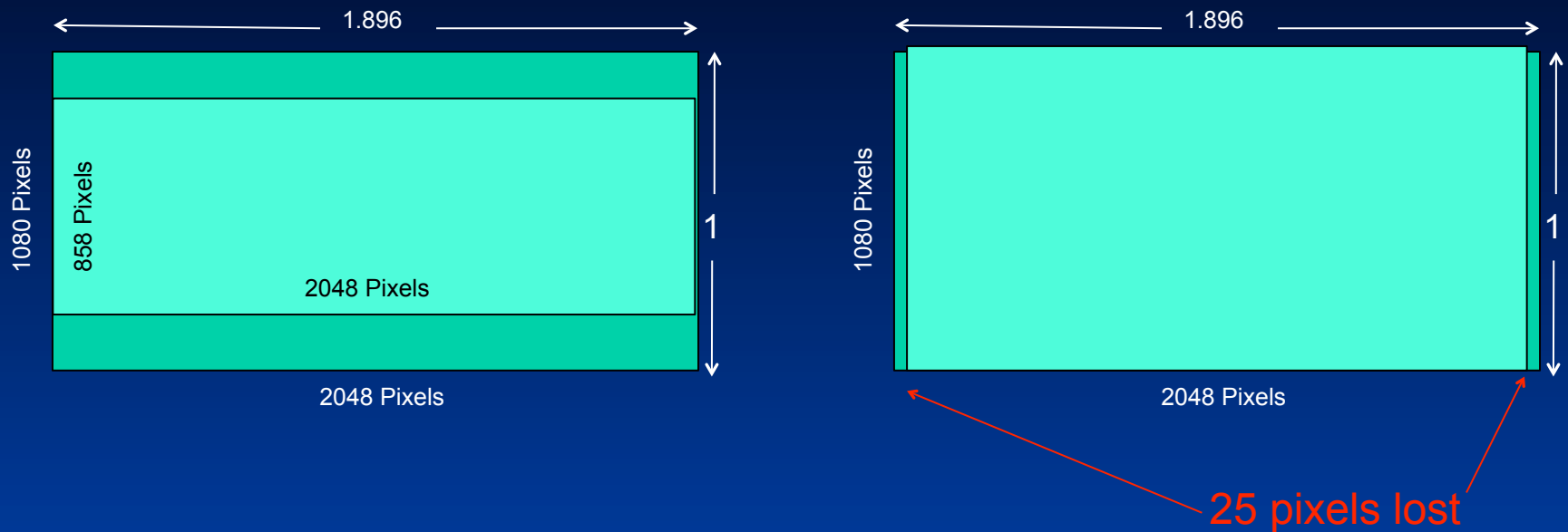

No Lens Change Needed
1.85 Image is High Resolution
2.39 Cinemascope is LOW resolution

Constant Width – With Anamorphic

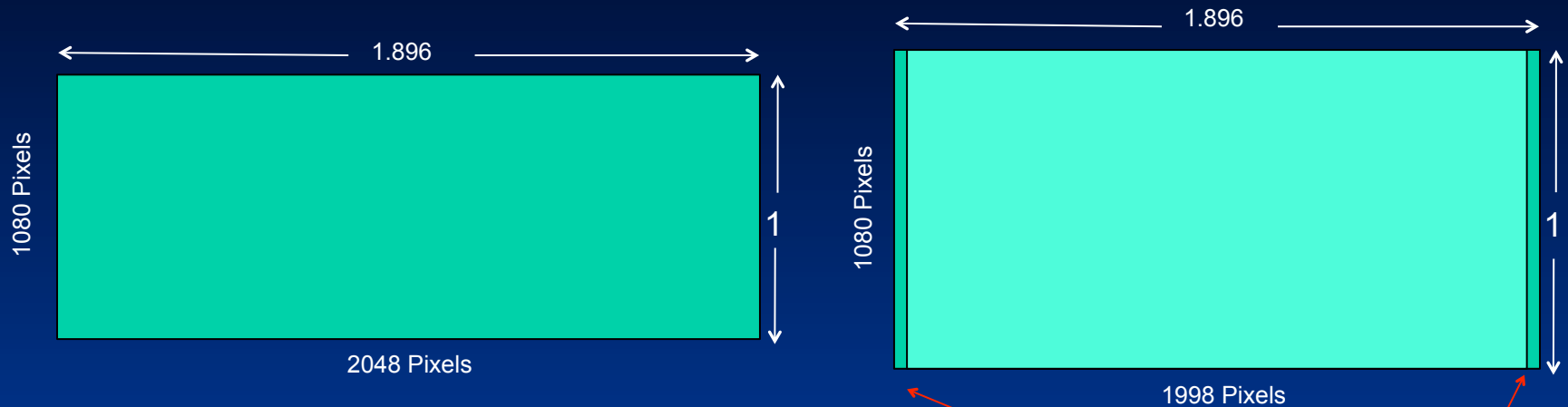

No pixels Lost !

25 pixels lost

Image Must be Scaled Vertically by 25%
Cinemascope Lens 25% Longer Focal Length
1.85 Image is High Resolution
2.39 Cinemascope is High Resolution

Use all the Resolution!

- Maximize the number of pixels you put on the screen
- Make sure those pixels are sharp, with good contrast
- Anamorphic lenses should be used when possible !!

Use all the Resolution!

- Not all lenses are designed for 4K
 - Image Circle
 - Resolution
- 4K lenses can be used for 2K, but not the other way `round.
- Don't use a 2K lens with a 4K projector – even if it “works”
- Don't make your 4K projector look like a 2K projector

Use All the Contrast !

- Choose your aperture
 - High Contrast Aperture (Cat Eye)
 - High Brightness Aperture (Round Aperture)
 - The high brightness aperture is lower contrast !!

TEST !!!

- Measure light levels
 - center and corner
 - From several positions in the auditorium
- Measure resolution
 - DC-2K pixels = 36 lp/mm
 - Mini 2K pixels = 46 lp/mm
 - DC-4K pixels = 66 lp/mm
- Evaluate Contrast Subjectively
- Remember – you have a GREAT piece of test equipment it's called a cinema

Resolution in Pixels

Resolution in pixels – 2K

CS full resolution (anam)	2048 x 1080	2,211,840	100%
CS letterbox	2048 x 858	1,757,184	79.44%
Flat full resolution	1998 x 1080	2,157,840	97.56%
Flat letterbox	1588 x 858	1,362,504	61.60%

Resolution in pixels - 4K

CS full resolution (anam)	4096 x 2160	8,847,360	100%
CS letterbox	4096 x 1716	7,028,736	79.44%
Flat full resolution	3996 x 2160	8,631,360	97.56%
Flat letterbox	3176 x 1716	5,450,016	61.60%

Which Aperture?

- High Contrast Aperture (cat eye)
- High Brightness Aperture (round)

1.25x Anamorphic Lenses

- Expand the image horizontally by 25%
- Allow the use of the entire chip for Cinemascope



A plea about lens size and picture size calculation

- We should name lenses by “focal length” and not by throw ratio
- We should do picture size calculations, including distortion, with good software.

DiStar+HD Series for 4K Mega Screen Projection



Many say they are the sharpest digital cinema lenses ever made. The new DiStar+HD lens series is optimized for 4K projectors with a 1.38" DLP chipset and they also work perfectly with 2K projectors with a 1.2" DLP chipset. Designed for theaters presenting on a slightly curved screen, DiStar+HD lenses offer brilliant, bright, uniformly illuminated images. They are just the ticket for huge screens and short throws.

Schneider today offers a suite of 5 wide-angle lenses with throw ratios between 0.8:1 and 1.36:1. And more of these superior DiStar lenses are on the way.

Lens Name	Focal Length	2K Throw Ratio	4K Throw Ratio	Screen Type	Availability
DiStar+HD	22.4mm	0.8:1	0.72:1	Flat	Available
DiStar+HD	24mm	0.9:1	0.85:1	Curved	Available
DiStar+HD	28mm	1.0:1	0.9:1	Curved	December 2011
DiStar+HD	29.4mm	1.05:1	0.95:1	Curved	January 2012
DiStar+HD	30.8mm	1.1:1	1.0:1	Curved	Available
DiStar+HD	32.2mm	1.15:1	1.04:1	Curved	February 2012
DiStar+HD	33.6mm	1.2:1	1.08:1	Curved	Available

Summary

- Use as many pixels as possible
- Use anamorphic lenses wherever possible for Cinemascope
- Use real 4K lenses for 4K
- Use a high contrast aperture wherever possible
- Always calculate picture size accurately with software during planning

Thank You!